

# GEMA-TEC A/S HAMMER MILL NuEvo FG



Type:  
FG 1500

The Hammer Mill NuEvo FG 1500 is a newly developed and newly designed fine grinding hammer mill, from GEMA-TEC A/S, with the following improvements:

- ◆ Heavy duty grinding chamber in 10 mm material thickness.
- ◆ Heavy duty door wheels for easy opening and closing of doors in both side in full length of grinding chamber.
- ◆ Stronger end covers which are bolted with double 10 mm bolts for fastening in the mill housing.
- ◆ Supplied with flanged bearing housing - Flange bearing housings are made of machined steel and are therefore stronger than traditional cast iron housings.
- ◆ The Hammer Mill is equipped with new constructed reinforced safety doors, in thickness 8,0 mm steel plate.
- ◆ New developed pneumatic safety door lock system - Pneumatic operated screen tension - Pneumatic operated open and closing of screen frame - Adjustable motor bracket.
- ◆ Built-in cable tray in the grinding chamber, for cables and pneumatic nylon hoses - Indicator and registration of open or closed doors.
- ◆ Grinding area in full length of Hammer Mill rotor - New special designed hammer mill energy rotor for higher capacity and optimal grinding proformas.
- ◆ Built-in guide plate for change of rotation direction - PT 100 temperature indicator on bearings.
- ◆ New designed grinding bridge, divided into removable elements - The grinding bridges are manufactured in machined steel plate and subsequently hardened - Grinding bridges in both top and bottom for more efficient and optimal grinding - The base frame is made of 10 mm plate and reinforced for mounting of a 455 kW motor.

## Application options

- ◆ Grain – Straw – Fishmeal - Meat and bone meal - Wood chips – Fiberglass ect.

## Screens

- ◆ Uses screens from  $\varnothing$  0,5 with 0,5 mm thickness and up to  $\varnothing$  50,0 mm in thickness.

## Screens

- ◆ Uses screens from  $\varnothing$  0,5 with 0,5 mm thickness and up to  $\varnothing$  50,0 mm in thickness

## Motor specification

- ◆ Max 455 kW – 3000 omdr. /min.

## Additional equipment

- ◆ Can be fitted with 0-speed guard.



**GEMA-TEC**  
FEED & PROCESS TECHNOLOGY

Pjedstedvej 109 · 7080 Børkop · DENMARK  
Tel:+45 75 86 80 15  
info@gema-tec.dk  
www.gema-tec.dk

# GEMA-TEC A/S HAMMER MILL NuEvo FG

Type	Hammer mill dimensions in mm											Weight (kg.) excl. motor
	A	B	C	D	E	F	G	H	J	K	L	
FG 1500	1500	855	1130	1660	1500	1150	1058	3540	75	1130	1130	3100

Technical data:	Type:	FG 1500
Motor Power	[kW]	200 - 455
Motor 50 / 60 Hz	[rpm. /m.]	3000/3600
Screen area	[dm <sup>2</sup> ]	133
Number of hammers	6 mm	148
Suction air	[m <sup>3</sup> /h]	6300

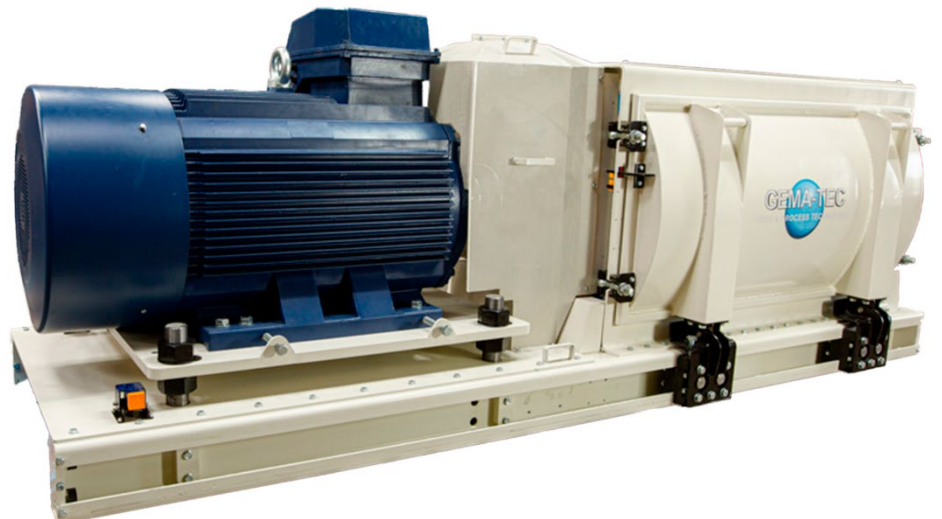
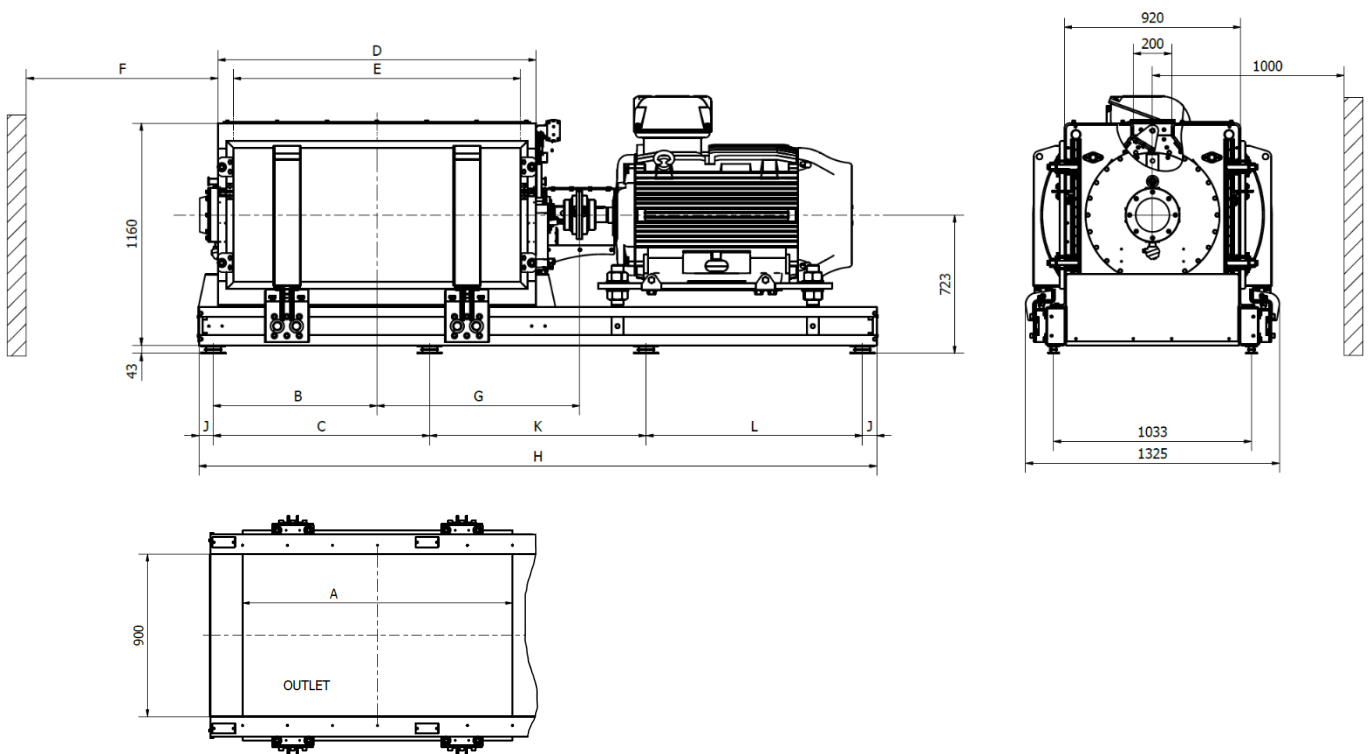

Subject to change without prior notice

F0003-2 - 16.12.19 GB